

2 Hrs Fire-rated Resistant Composite Door



A Fire-Rated Resistant Composite Door is a type of door designed to withstand fire for a specific period to help contain the spread of flames and smoke. These doors are commonly used in commercial buildings, homes, hotels, and industrial spaces where fire safety is a priority.

Contact Us



Sunstar Door



+6010-280 8080

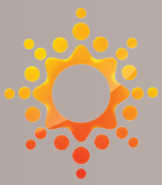

SUNSTAR

Quality Fire-rated Door

- * 2 Hours Rated Fire Resistance
- * BS EN 12209:2003 Standard and ANSI / BHMA A 156.13:2003 Compliance Ironmongeries
- * Tested And In Compliance To Ms 1073: Part 3: 1996 (AMD. 1: 2003)
- * Electro Galvanised Metal Door Frame
- * Spot Welded Type Hinges

Typical Door Jamb Section

Double Rebated

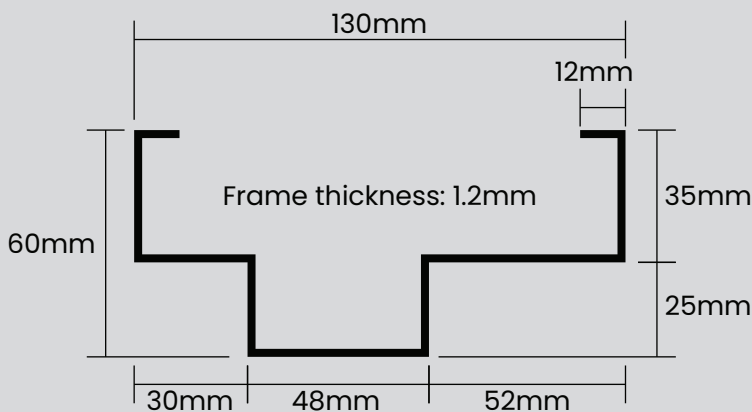

Single Rebated

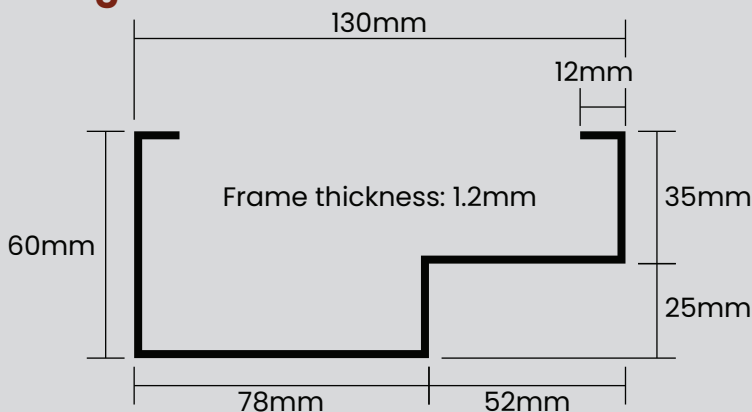

Door Frame Size

Max. Single Leaf Frame - 1220mm (W) x 2450mm (H)

Max. Double Leaf Frame - 2430mm (W) x 2450mm (H)

Single Leaf Two Hours Fire Rated Door With Electro Galvanized Metal Door Frame

Maximum Size 1220mm x 2450mm

Model: 2hrs/sl/mf

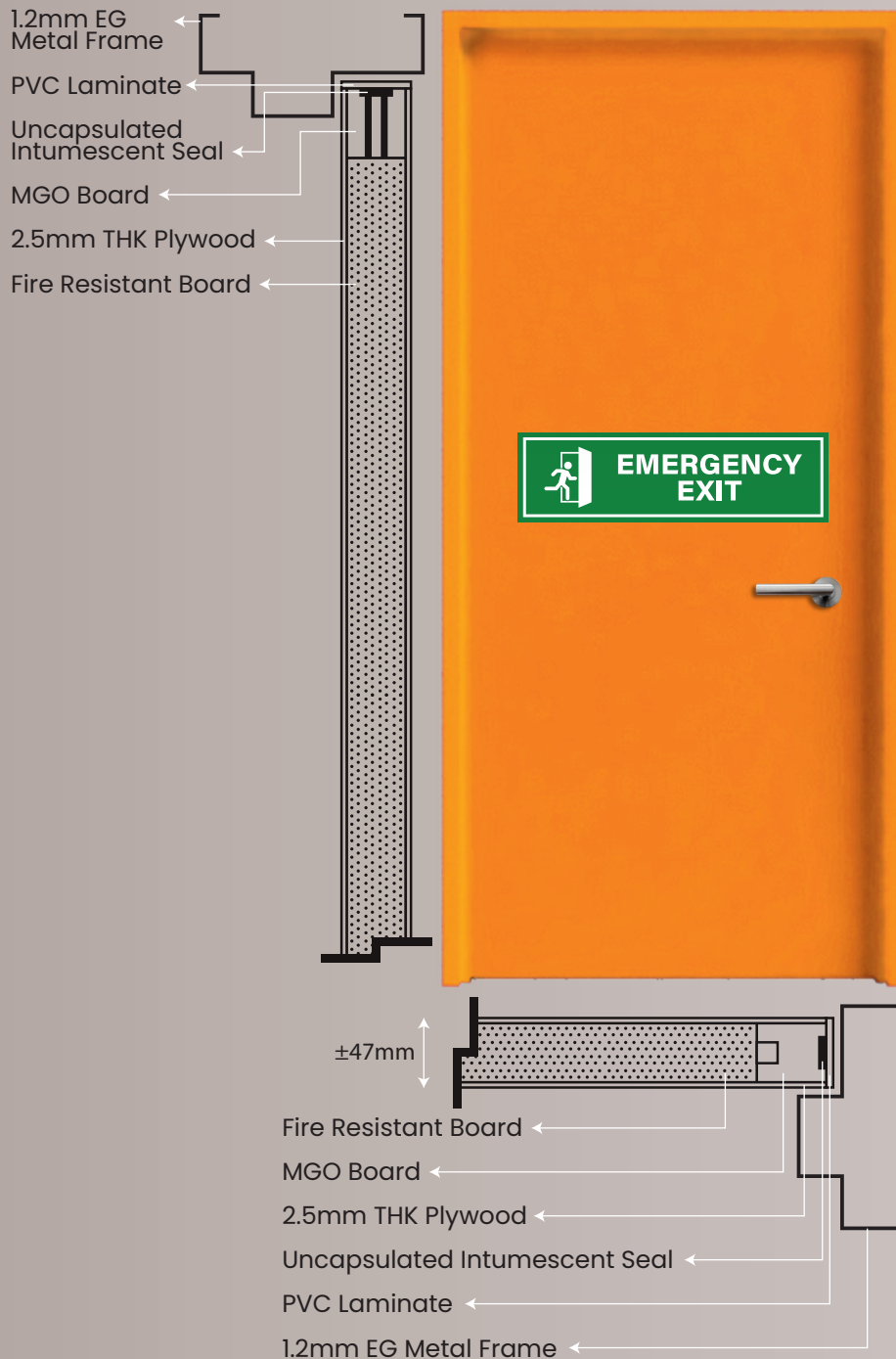

Surface Mounted Door Closer



Mortise Lever Set



Stainless Steel Hinges